



深圳大夏龙雀科技有限公司  
Shenzhen DX-SMART Technology Co Ltd.

DX-BT24 蓝牙模块  
DX-BT24 Bluetooth Module

Note: English instructions go to page 16  
(英文说明书请跳转到第16页)

技  
术  
手  
册 v 2.1



## 目录

一、概述	3
二、模块默认参数	3
三、应用领域	3
四、功耗参数	4
五、射频特性	4
六、透传参数	4
七、模块引脚说明及最小电路图	5
八、管脚功能描述	5
九、功能引脚详细说明	6
十、外形尺寸	7
十一、LAYOUT 注意事项	7
十二、AT 指令集	9
12.1 测试指令	10
12.2 获取软件版本号	10
12.3 查询—蓝牙地址码	10
12.4 设置\查询—设备名称	10
12.5 设置\查询—串口波特率	10
12.6 设置\查询—串口停止位	11
12.7 设置\查询—串口校验位	11
12.8 设置\查询—通知上位机连接状态	12
12.9 设置\查询—通知连接含地址码	12
12.10 设置\查询—服务 SERVICE UUID	12
12.11 设置\查询—通知 NOTIFY UUID\写入 WRITE UUID	12
12.12 设置\查询—写入 WRITE UUID	13
12.13 设置\查询—低功耗模式	13
12.14 设置\查询—广播时间间隔	13
12.15 设置\查询—模块发射功率	14
12.16 软件重启	14
12.17 恢复出厂设置	15
十三、联系我们	15



## 一. 概述

DX-BT24 5.0蓝牙模块是深圳大夏龙雀科技有限公司专为智能无线数据传输而打造，采用英国DAILOG公司14531芯片，配置256Kb空间，遵循V5.0 BLE蓝牙规范。支持AT指令，用户可根据需要更改串口波特率、设备名称等参数，使用灵活。

本模块支持UART接口，并支持蓝牙串口透传，具有成本低、体积小、功耗低、收发灵敏性高等优点，只需配备少许的外围元件就能实现其强大功能。

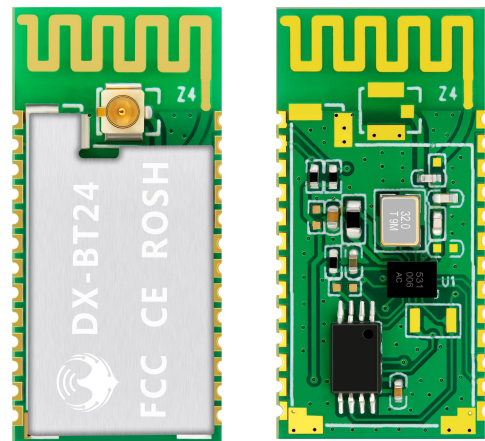

## 二. 模块默认参数:

蓝牙协议	Bluetooth Specification V5.0 BLE
工作频率	2.4GHz ISM band
通信接口	UART
供电电源	3.3V
天线	可以选择PCB板载天线、或外接DB天线(默认为PCB天线)
通信距离	30-40M (空旷环境)
外观尺寸	27(L)mm x 13 (W)mm x 2(H) mm
蓝牙认证	FCC CE ROHS REACH
蓝牙名称	BT24
串口参数	9600、8数据位、1停止位、无校验、无流控
空中升级	不支持
Service UUID	FFE0
Notify & Write UUID	FFE1
Write UUID	FFE2
Work temperature	MIN:-40℃ - MAX:+85℃
定制需求	如有其它特殊功能要求，可以联系我司，对模块进行定制

## 三. 应用领域:

DX-BT24 模块同时支持 BT5.0 BLE 协议，可以同具备 BLE 蓝牙功能的 iOS 设备直接连接，支持后台程序常驻运行。主要用于短距离的数据无线传输领域。避免繁琐的线缆连接，能直接替代串口线。**BT24 模块成功应用领域:**

- ※ 蓝牙无线数据传输;
- ※ 手持 POS 设备;
- ※ 智能家居控制;
- ※ 蓝牙遥控玩具;
- ※ 手机、电脑周边设备;
- ※ 医疗设备无线数据传输;
- ※ 蓝牙打印机;
- ※ 共享单车;



#### 四. 功耗参数

广播间隔 540ms 下			
模式	状态	电流	Unit
低功耗模式	Discoverable	32	uA
	Connected	341	uA
正常工作模式	Discoverable	270	uA
	Connected	341	uA
透传数据时 (11520Bytes/s)	Connected	MIN:341uA MAX:3.5	mA

#### 五. 射频特性

Rating	Value	Unit
BLE 发射功率	-19.5~+2.5	dBm
BLE 灵敏度	-94	dBm

#### 六. 透传参数

数据吞吐量:

Android ->BT24 -> UART		UART ->BT24 -> Android	
波特率	115200	波特率	115200
连接间隔时间(ms)	15	连接间隔时间(ms)	15
APP 数据包大小(bytes)	200	串口数据包大小(bytes)	240
发送间隔(ms)	20	发送间隔(ms)	20
吞吐量(bytes/s)	8280	吞吐量(bytes/s)	7680
Characteristic 写方式	Write without Response	Characteristic 通知方式	Notify
iPhone ->BT24 -> UART		UART ->BT24 -> iPhone	
波特率	115200	波特率	115200
连接间隔时间(ms)	30	连接间隔时间(ms)	30
APP 数据包大小(bytes)	140	串口数据包大小(bytes)	180
发送间隔(ms)	20	发送间隔(ms)	50
吞吐量(bytes/s)	5600	吞吐量(bytes/s)	3240
Characteristic 写方式	Write without Response	Characteristic 通知方式	Notify



注：此表格参数仅做参考，不代表模组能支持的最大数据吞吐量。

## 七. 模块引脚说明及最小电路图：

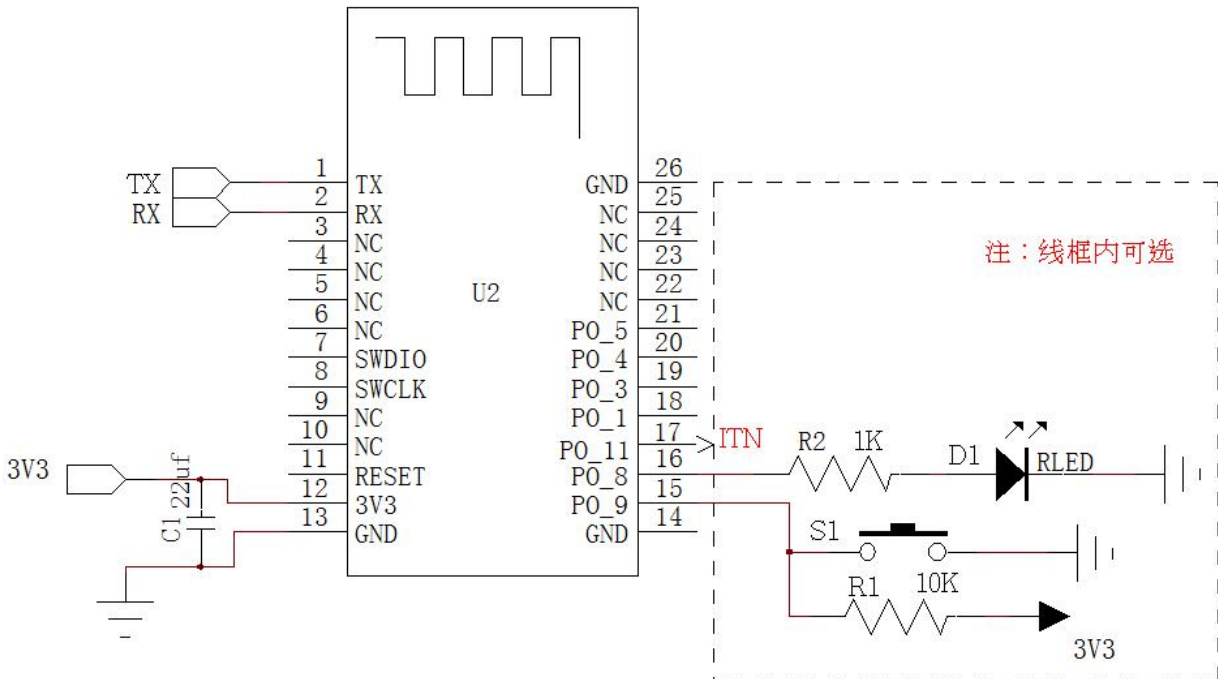

## 八. 管脚功能描述：

管脚序号	管脚名称	管脚说明
1	TX	串口数据输出
2	RX	串口数据输入
3	NC	悬空
4	NC	悬空
5	NC	悬空
6	NC	悬空
7	SWDIO	调试数据口
8	SWCLK	调试时钟口
9	NC	悬空
10	NC	悬空
11	Reset	复位脚（输入200ms高电平脉冲）



12	VCC	电源 V3.3
13	GND	地
14	GND	地
15	PO_9	断开连接引脚(200ms 低电脉冲断开) 低功耗模式唤醒 (200ms 低电脉冲唤醒)
16	PO_8	LED 灯管脚 (未连接: 1s 亮 1s 灭, 连接: 3s 亮 50ms 灭)
17	P1_11	蓝牙连接指示口 (未连接为低, 连接上为高)
18	NC	悬空 (只能悬空)
19	NC	悬空 (只能悬空)
20	NC	悬空 (只能悬空)
21	PO_5	可编程输入输出
22	NC	悬空
23	NC	悬空
24	NC	悬空
25	NC	悬空
26	GND	地

## 九. 功能引脚详细说明

### 1、16 脚 (PO\_8) : LED 灯指示引脚

- 用于指示蓝牙模块所处状态, LED灯闪烁方式与蓝牙模块状态对应见下表:

模块	LED 显示	模块状态
从模块	均匀慢速闪烁 (1s-on, 1s-off)	待机状态
	亮 3s 灭 50ms (3s-on, 50ms-off)	连接状态
	低功耗模式下灯灭	

### 2、17 脚 (P1\_11) : 连接状态指示脚

引脚状态	模块状态
输出低电平	待机状态
输出高电平	连接状态

### 3、15 脚 (PO\_9) : 连接中断脚 (模块处于连接状态有效)

引脚状态	模块状态
无动作	连接状态
从模块输入 200ms 低电平脉冲	中断连接, 模块进入低功耗模式



	(进入之前设置的工作模式，如未设置则是正常工作模式)
--	----------------------------

4、15 脚(P0\_9):低功耗模式唤醒脚 (模块处于低功耗模式有效)

引脚状态	模块状态
无动作	低功耗模式
从模块输入 200ms 低电平脉冲	从低功耗模式唤醒，模块进入待机状态

5、低功耗和正常工作模式对比

	正常工作模式	低功耗模式
AT 指令	上电即可发送 AT 指令	<b>PO_9: 200ms 低电脉冲唤醒才能发 AT 指令</b>
灯状态	均匀慢速闪烁	<b>灯不亮</b>

十. 外形尺寸:

**厚度: 2.3mm±0.2mm**

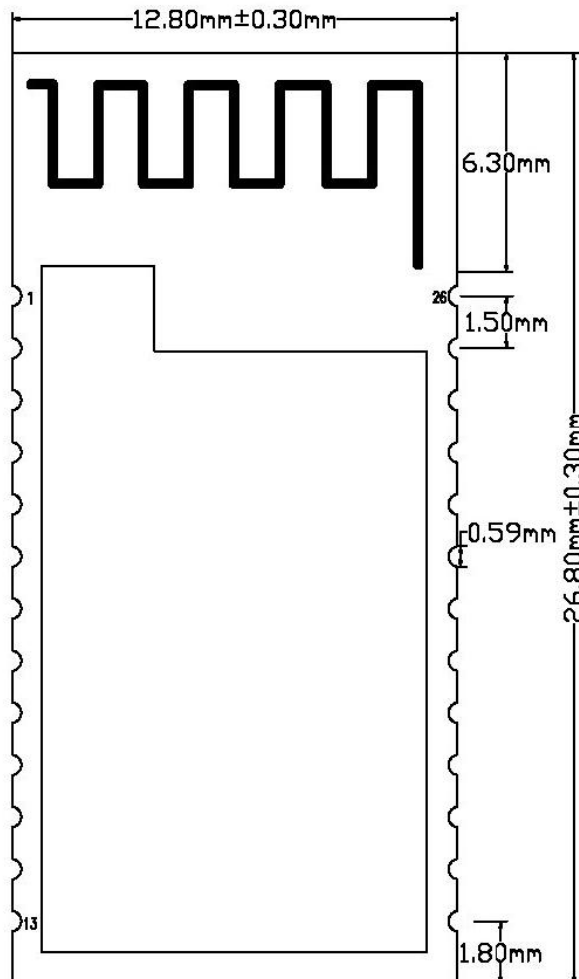



## 十一. LAYOUT 注意事项

DX-BT24 蓝牙模块工作在2.4G无线频段，应尽量避免各种因素对无线收发的影响，注意以下几点：

- 1、包围蓝牙的产品外壳避免使用金属，当使用部分金属外壳时，应尽量让模块天线部分远离金属部分。产品内部金属连接线或者金属螺钉，应尽量远离模块天线部分。
- 2、模块天线部分应靠载板PCB 四围放置，不允许放置于板中，且天线下方载板铣空，与天线平行的方向，不允许铺铜或走线、或直接把天线部分直接露出载板。
- 3、建议在基板上的模块贴装位置使用绝缘材料进行隔离，例如在该位置放一个整块的丝印（TopOverLay）

(推荐)

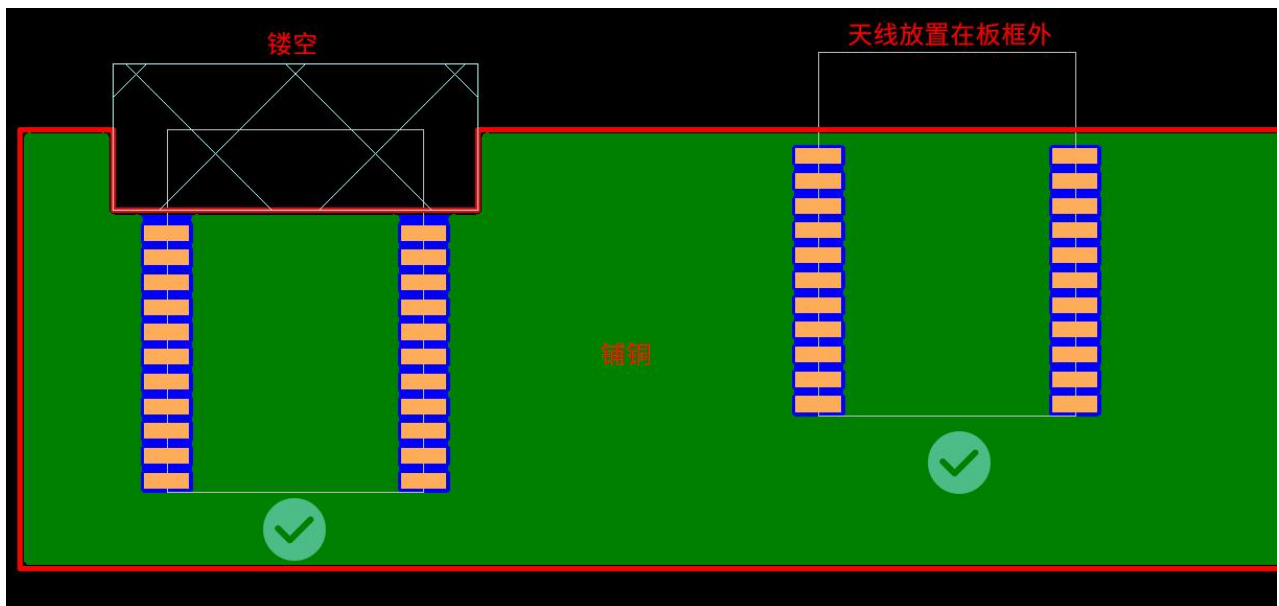

(不推荐)

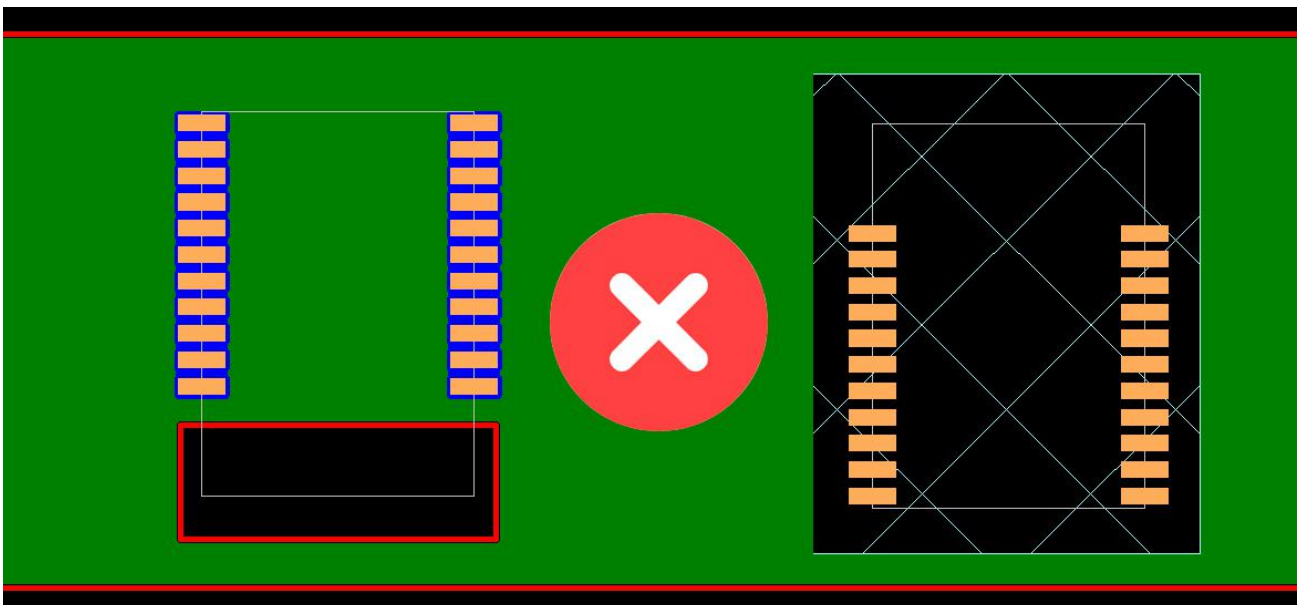





## 十二. AT 指令集 (注: 模块上电未连接时即为AT指令模式)

- 1、AT 指令, 属于字符串指令, 按行解析 (即发 AT 指令时必须以回车换行或者\r\n、16 进制为 0D0A 结尾)
- 2、AT 指令为大写, 指令前缀为 AT+, 可分为参数设置指令和读取指令。
- 3、设置指令格式: AT+<CMD><PARAM>操作成功返回: +<CMD>=<PARAM>\r\n OK\r\n 失败不返回字符。除第 6、7 项设置外, 其他项设置参数后需重启模块, 新参数才生效。
- 4、读取指令格式: AT+<CMD>操作成功返回: +<CMD>=<PARAM>\r\n 失败不返回字符。

AT 命令格式举例(图一为 AT 测试命令, 图二为将蓝牙名称改为 1234):

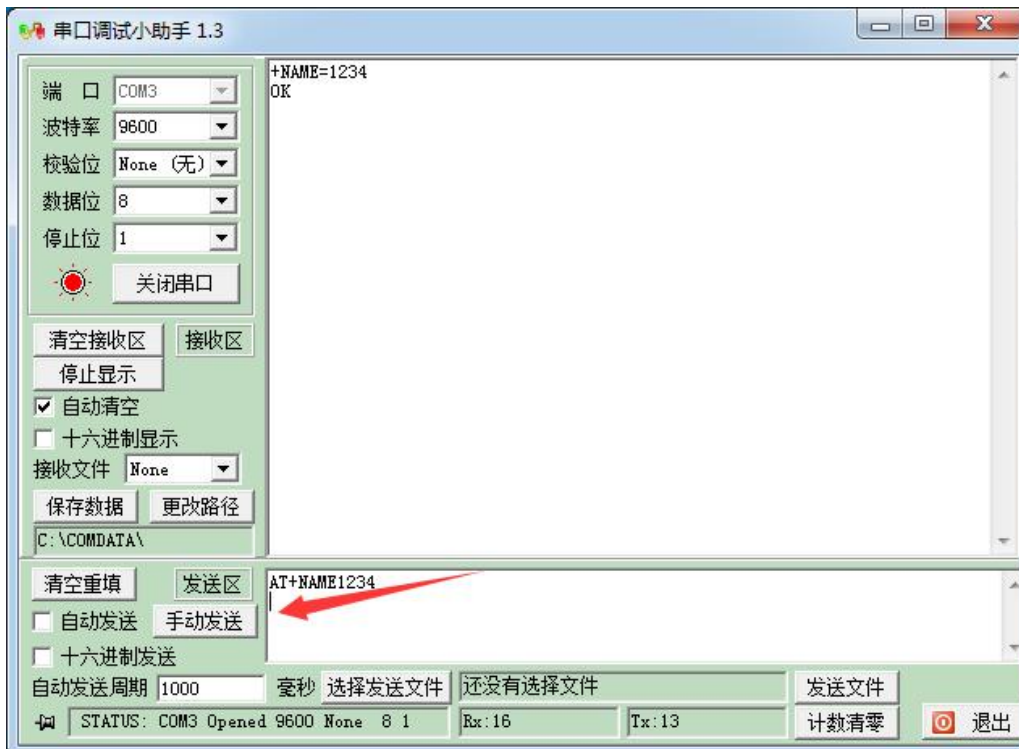
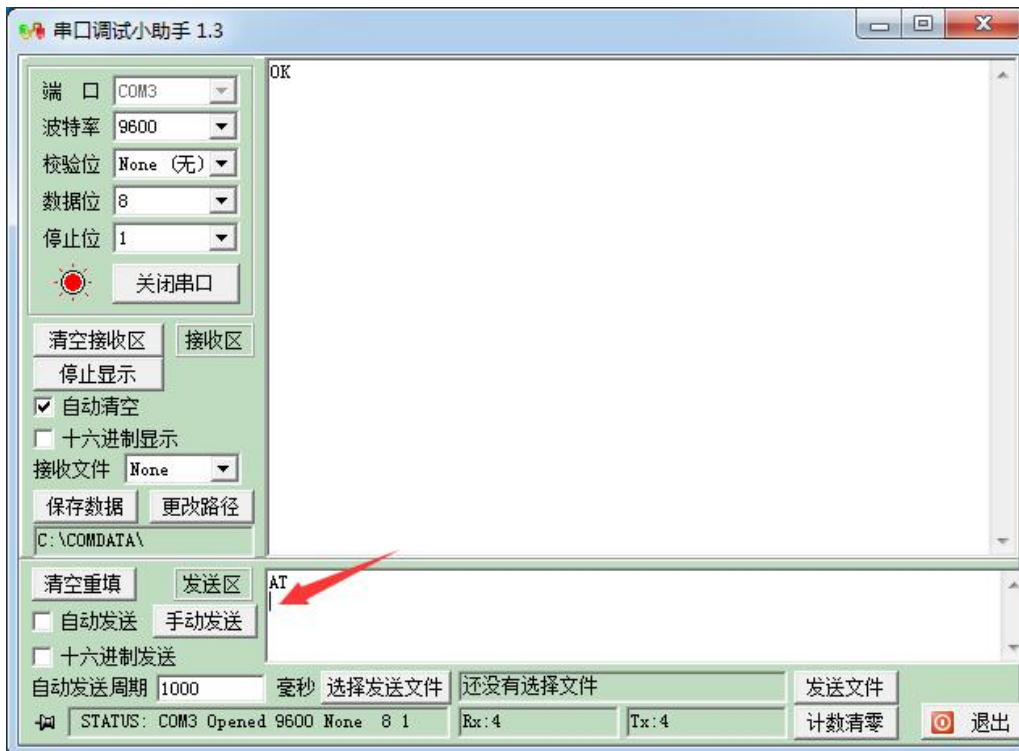





查询模块波特率	AT+BAUD\r\n	+BAUD=<baud>\r\n	<baud>波特率对应序号 1:2400 2:4800 3:9600 4:19200 5:38400 6:57600 7:115200 8:230400 默认值: 3 (9600)
设置模块波特率	AT+BAUD<baud>\r\n	+BAUD=<baud>\r\n OK\r\n	

示例：设置串口波特率：57600

1. 发送设置：

AT+BAUD6\r\n

返回：

+BAUD=6\r\n

OK\r\n

2. 发送查询：

AT+BAUD\r\n

返回：

+BAUD=6\r\n

6、设置\查询—串口停止位：

功能	指令	响应	说明
查询模块串口停止位	AT+STOP\r\n	+STOP=<Param>\r\n	< Param>停止位 0-1 停止位 1-2 停止位 默认值： 0
设置模块串口停止位	AT+STOP<Param>\r\n	+STOP=<Param>\r\n OK	

7、设置\查询—串口校验位：

功能	指令	响应	说明
查询模块串口校验位	AT+PARI\r\n	+PARI=<Param>\r\n	< Param>校验位 0-1 无校验 1-2 奇校验 2-2 偶校验 默认值： 0
设置模块串口校验位	AT+PARI<Param>\r\n	+PARI=<Param>\r\n OK	



8、设置\查询—通知上位机连接状态：连接成功模块返回 OK+CONN

功能	指令	响应	说明
查询通知上位机连接 状态	AT+NOTI\r\n	+NOTI=<Param>\r\n	< Param>校验位 0-不通知
设置通知上位机连接 状态	AT+NOTI<Param>\r\n	+NOTI=<Param>\r\n OK	1-通知 默认值：0

9、设置\查询—通知连接含地址码：连接成功模块返回 OK+CONN0x112233445566

功能	指令	响应	说明
查询通知上位机连接 状态	AT+NOTP\r\n	+NOTP=<Param>\r\n	< Param>校验位 0-不通知
设置通知上位机连接 状态	AT+NOTP<Param>\r\n	+NOTP=<Param>\r\n OK	1-通知 默认值：0

10、设置\查询—服务 SERVICE UUID：（修改完之后要重启手机蓝牙，手机才生效）

功能	指令	响应	说明
查询模块服务 UUID	AT+UUID\r\n	+UUID =<service>\r\n	<service>服务 UUID 默认服务 UUID:
设置模块服务 UUID	AT+UUID<service>\r\n	+UUID =<service>\r\n OK	FFE0

示例：设置服务 UUID 为：FF00

1. 发送设置：

AT+UID0xFF00\r\n

返回：

+UID=0xFF00 r\n

OK

11、设置\查询—通知 NOTIFY UUID\写入 WRITE UUID：（修改完之后要重启手机蓝牙，手机才生效）

功能	指令	响应	说明
----	----	----	----



查询模块通知\写入 UUID	AT+CHAR\r\n	+CHAR=<UUID >\r\n	<UUID>通知\写入 UUID
设置模块通知\写入 UUID	AT+CHAR<UUID>\r\n	+CHAR=<UUID>\r\n OK	默认值： FFE1

注：此通道是为可读写通道（即可以读也可写）

示例：设置通知\写入 UUID 为： FE01

1. 发送设置：

AT+CHAR0xFE01\r\n

返回：

+ CHAR=FE01r\n

OK\r\n

12、设置\查询—写入 WRITE UUID ：（修改完之后要重启手机蓝牙，手机才生效）

功能	指令	响应	说明
查询模块写入 UUID	AT+WRITE\r\n	+WRITE=<UUID >\r\n	<UUID>写入 UUID
设置模块写入 UUID	AT+WRITE<UUID>\r\n	+ WRITE=<UUID>\r\n OK	默认值： FFE2

13、设置\查询—低功耗模式：

功能	指令	响应	说明
查询模块低功耗模式	AT+PWARM\r\n	+PWARM=<Param>\r\n	< Param > (0、1)
设置模块低功耗模式	AT+PWARM<Param>\r\n n	+PWARM=<Param>\r\n OK	0：低功耗模式 1：正常工作模式 默认值： 1

14、设置/查询—广播时间间隔：

功能	指令	响应	说明
查询模块广播时间间隔	AT+ ADVI \r\n	+ ADVI =<Param>\r\n	Param: 0~F



设置模块广播时间间隔	AT+ADVI<Param>\r\n	+ADVI=<Param>\r\n OK	0—100ms 1—152.5ms 2—211.25ms 3—318.75ms 4—417.5ms 5—546.25ms 6—760ms 7—852.5ms 8—1022.5ms 9—1285ms A—2000ms B—3000ms C—4000ms D—5000ms E—6000ms F—7000ms 默认设置：5
------------	--------------------	-------------------------	---

注：此指令可以用于降低功耗

15、查询/设置—模块发射功率：

功能	指令	响应	说明
查询模块发射功率	AT+POWE\r\n	+POWE=<POWE>\r\n	<POWE>: 1: -19.5 dB 2: -13.5 dB 3: -10dB 4: -7dB 5: -5dB 6: -3.5dB 7: -2dB 8: -1dB 9: 0dB A: +1dB B: +1.5dB C: +2.5dB
设置模块发射功率	AT+POWE<POWE>\r\n	+POWE=<POWE>\r\n OK\r\n	默认：C

16、软件重启：

功能	指令	响应	说明
软件重启	AT+RESET\r\n	OK\r\n	



17、恢复出厂设置:

功能	指令	响应	说明
恢复出厂设置	AT+DEFAULT\r\n	OK\r\n	

### 十三. 联系我们

#### 深圳大夏龙雀科技有限公司

地址：深圳市宝安区固戍二路裕兴科技园(裕兴创谷)C栋511

电话：0755-2997 8125

传真：0755-2997 8369

网址：<http://www.szdx-smart.com/>



## Table Of Contents

1、 Overview .....	17
2、 Module Default Parameters .....	17
3、 Application Area.....	18
4、 Power consumption parameters.....	18
5、 Radio frequency characteristics.....	18
6、 Transparent Transmission Parameters .....	18
7、 Module Pin Description And Minimum Circuit Diagram.....	19
8、 Pin Function Description .....	20
9、 Detailed Description Of Function pins.....	21
10、 Dimensions .....	22
11、 LAYOUT Precautions.....	22
12、 AT COMMAND.....	24
12.1 Test Command .....	25
12.2 Get The Software Version.....	25
12.3 Query Module Bluetooth MAC.....	25
12.4 Set/Query Device Name.....	26
12.5 Set/Query - Serial Port Baud Rate.....	26
12.6 Set/Query - Serial Port Stop Bit:.....	27
12.7 Set / Query - Serial Parity Bit: .....	27
12.8 Set/Query-Notify the host computer connection status.....	27
12.9Set/Query - Notification connection with address code.....	27
12.10Settings\Query - SERVICE UUID.....	28
12.11 Settings\Query - NOTIFY UUID\ WRITE UUID .....	28
12.12Settings\Query - WRITE UUID .....	28
12.13 Settings\Query - Low Power Mode.....	29
12.14 Settings\Query - Broadcast time interval.....	29
12.15Settings\Query - Module transmit power.....	29
12.16 Software restart.....	30
12.17Restore default settings.....	30
13、 Contact Us.....	30





## 1. Overview

DX-BT24 5.0 Bluetooth module is built by Shenzhen DX-SMART Technology Co., Ltd. for intelligent wireless data transmission. It adopts CC2541 chip of American TI Company, configures 256Kb space, and follows V5.0 BLE Bluetooth specification. Support AT command, users can change the serial port baud rate, device name, pairing password and other parameters as needed, flexible use.

This module supports UART interface and supports Bluetooth serial port transparent transmission. It has the advantages of low cost, small size, low power consumption, high sensitivity of sending and receiving, etc. It can realize its powerful functions with only a few peripheral components simple operation, high cost performance and technology leading edge.

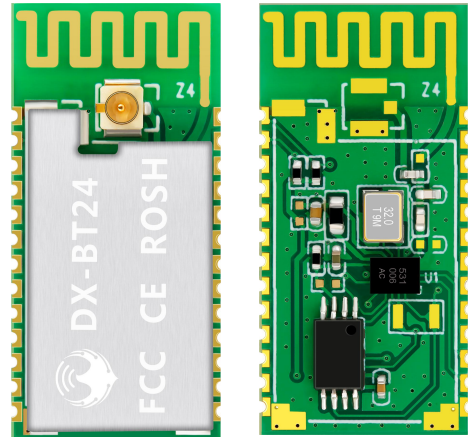

## 2. Module default parameters:

<b>Bluetooth Protocol</b>	Bluetooth Specification V5.0 BLE
<b>Working Frequency</b>	2.4GHz ISM band
<b>Communication Interface</b>	UART
<b>Power Supply</b>	3.3V
<b>Communication distance</b>	30-40M (Open and unobstructed environment)
<b>Physical Dimension</b>	18.5(L)mm x 13.5(W)mm x 2(H) mm
<b>Bluetooth Authentication</b>	FCC CE ROHS REACH
<b>Bluetooth Name</b>	BT24
<b>Serial Port Parameters</b>	9600、8 data bits、1 stop bit、No check、No flow control
<b>Service UUID</b>	FFE0
<b>Notify\Write UUID</b>	FFE1
<b>Write UUID</b>	FFE2
<b>Work temperature</b>	MIN:-40℃ - MAX:+85℃
<b>Customized requirements</b>	If you have other special function requirements, you can contact us to customize the module.



### 3. Application area:

DX-BT24 module supports BT5 .0 BLE protocol, which can be directly connected to iOS devices that have BLE Bluetooth function, and supports background program resident operation.

Successful application of BT24 module:

- ※ Bluetooth wireless data transmission;
- ※ Mobile phones, computer peripherals;
- ※ Handheld POS device;
- ※ Medical equipment wireless data transmission;
- ※ Smart Home Control;
- ※ Automotive Inspection OBD Equipment;
- ※ Bluetooth printer;
- ※ Bluetooth remote control toy;
- ※ Anti-lost device, LED light control;

### 4. Power consumption parameters:

Broadcast interval: 540ms			
Mode	Status	Current	Unit
Low power mode	Discoverable	32	uA
	Connected	341	uA
Normal working mode	Discoverable	270	uA
	Connected	341	uA
When transparently transmitting data(11520Bytes/s)	Connected	MIN:341uA MAX:3.5	mA

### 5. Radio frequency characteristics:

Rating	Value	Unit
BLE Transmit power	-19.5~+2.5	dBm
BLE Sensitivity	-94	dBm

### 6. Transparent transmission parameters

#### Data throughput:

Android ->BT24 -> UART	UART ->BT24 -> Android
------------------------	------------------------



Baud rate	115200	Baud rate	115200
Connection interval (ms)	15	Connection interval (ms)	15
Serial packet size (bytes)	200	Serial packet size (bytes)	240
Transmission interval (ms)	20	Transmission interval (ms)	20
Throughput (bytes/s)	8280	Throughput (bytes/s)	7680
Characteristic Write	Write without Response	Characteristic Notify	Notify
<b>iPhone 6 -&gt;BT24 -&gt; UART</b>		<b>UART -&gt;BT24 -&gt; iPhone 6</b>	
Baud rate	115200	Baud rate	115200
Connection interval (ms)	30	Connection interval (ms)	30
Serial packet size (bytes)	140	Serial packet size (bytes)	180
Transmission interval (ms)	20	Transmission interval (ms)	50
Throughput (bytes/s)	5600	Throughput (bytes/s)	3240
Characteristic Write	Write without Response	Characteristic Notify	Notify

Note: This table parameter is for reference only and does not represent the maximum data throughput that the module can support.

## 7. Module pin description and minimum circuit diagram:

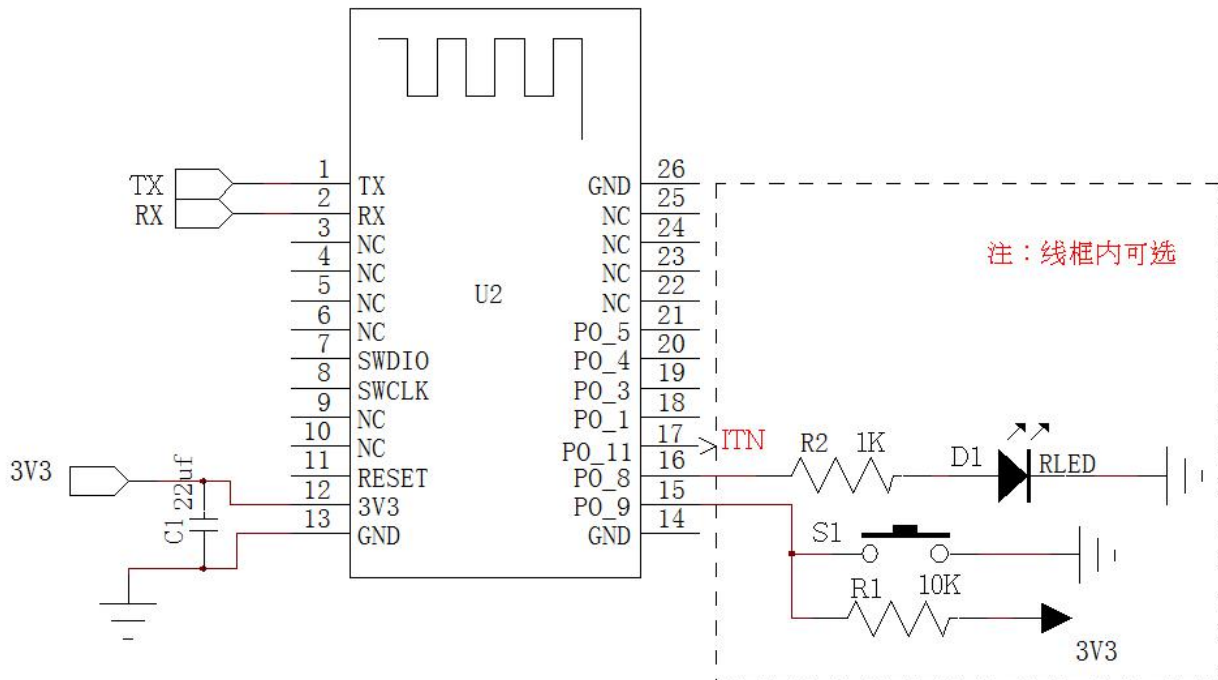



## 8. Pin function description:

Pin number	Pin name	Pin description
1	P0_6	Serial data output
2	P0_7	Serial data input
3	NC	NC
4	NC	NC
5	NC	NC
6	NC	NC
7	P0_10	Debug data port
8	P0_2	Debug clock port
9	NC	NC
10	NC	NC
11	Reset	Reset ( Input 200ms high level pulse )
12	VCC	V3.3
13	GND	Land
14	GND	Land
15	P0_9	Disconnect pin(200ms low power pulse disconnection) Low power mode wake up(200ms low power pulse wake up)
16	P0_8	LED light pin(Not connected: 1s on, 1s off, connected: 3s on, 50ms off)
17	P1_11	Bluetooth connection indicator (not connected low, connection high)
18	NC	NC ( Can only be left floating )
19	NC	NC ( Can only be left floating )
20	NC	NC ( Can only be left floating )
21	P0_5	Programmable input and output
22	NC	NC
23	NC	NC
24	NC	NC
25	NC	NC
26	GND	Land



## 9. Detailed description of function pins:

### 1、16 feet (P0\_8): LED indicator pin

• Used to indicate the status of the Bluetooth module, the LED flashing mode corresponds to the status of the Bluetooth module, see the table below:

Module	LED display	Module status
Slave module	Flashes slowly and evenly (1s-on, 1s-off)	standby mode
	Bright 3s Extinguish 50ms (3s-on, 50ms-off)	Connection Status
	Light off in low power mode	

### 2、Pin 17 (P1\_11): connection status indication pin

Pin status	Module status
Output low	standby mode
Output high level	Connection Status

### 3、Pin 15 (P0\_9): connection interruption pin (the module is in the connected state is valid)

Pin status	Module status
No action	Connection Status
Input 200ms low-level pulse from the module	The connection is interrupted and the module enters low power consumption mode (Enter the previously set working mode, if not set, it is the normal working mode)

### 4、Pin15 (P0\_9): low-power mode wake-up pin (the module is effective in low-power mode)

Pin status	Module status
No action	Low power mode
Input 200ms low-level pulse from the module	Wake up from low power mode, the module enters the standby state

### 5、Comparison of low power mode and normal working mode

	Normal working mode	Low power mode
AT command	Send AT commands after power-on	P0_9: 200ms low power pulse wake up to send AT command
Light status	Even slow blinking	light is not on



## 10. Dimensions:

厚度:  $2.3\text{mm} \pm 0.2\text{mm}$

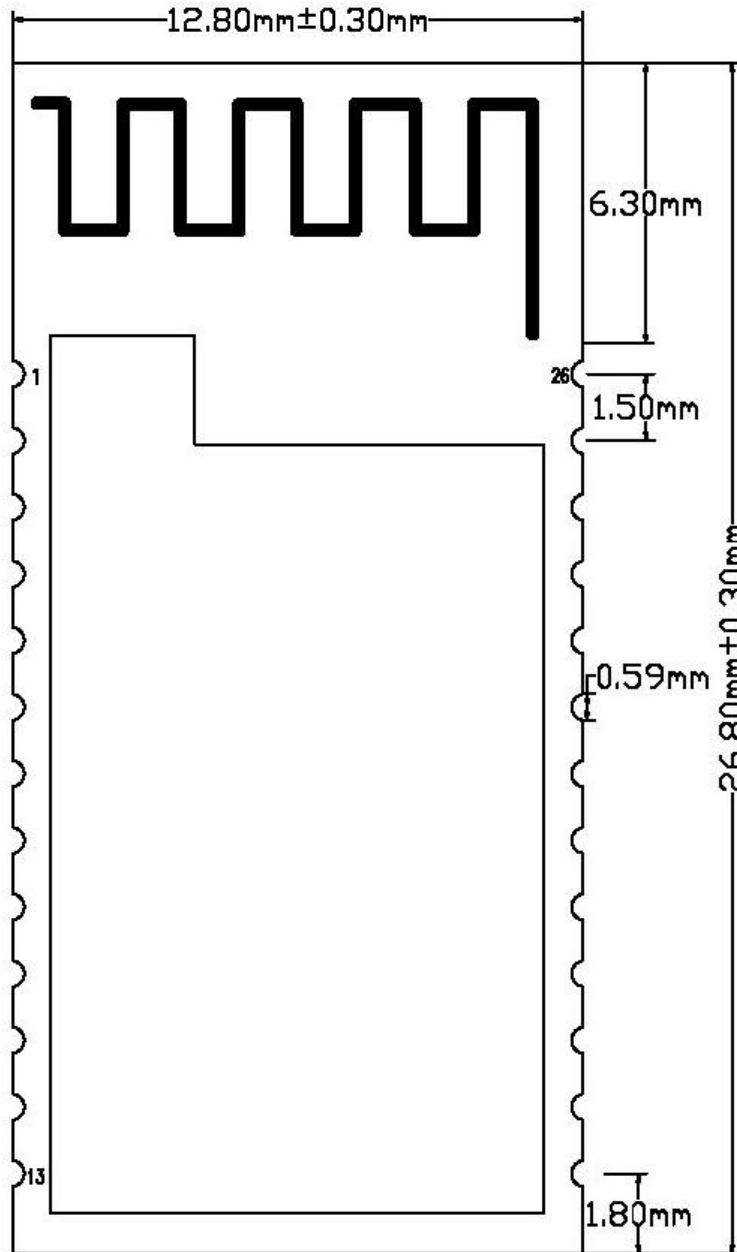

## 11. LAYOUT Precautions:

The DX-BT24 Bluetooth module works in the 2.4G wireless band. It should try to avoid the influence of various factors on the wireless transceiver. Pay attention to the following points:

1. the product shell surrounding the Bluetooth module to avoid the use of metal, when using part of the metal shell, should try to make the module antenna part away from the metal part.



2. The internal metal connecting wires or metal screws of the product should be far away from the antenna part of the module.

3. The antenna part of the module should be placed around the PCB of the carrier board. It is not allowed to be placed in the board, and the carrier board under the antenna is slotted. The direction parallel to the antenna is not allowed to be copper or traced. It is also a good choice to directly expose the antenna part out of the carrier board.

4. It is recommended to use insulating material for isolation at the module mounting position on the substrate. For example, put a block of screen printing (TopOverLay) at this position.

(Recommend)

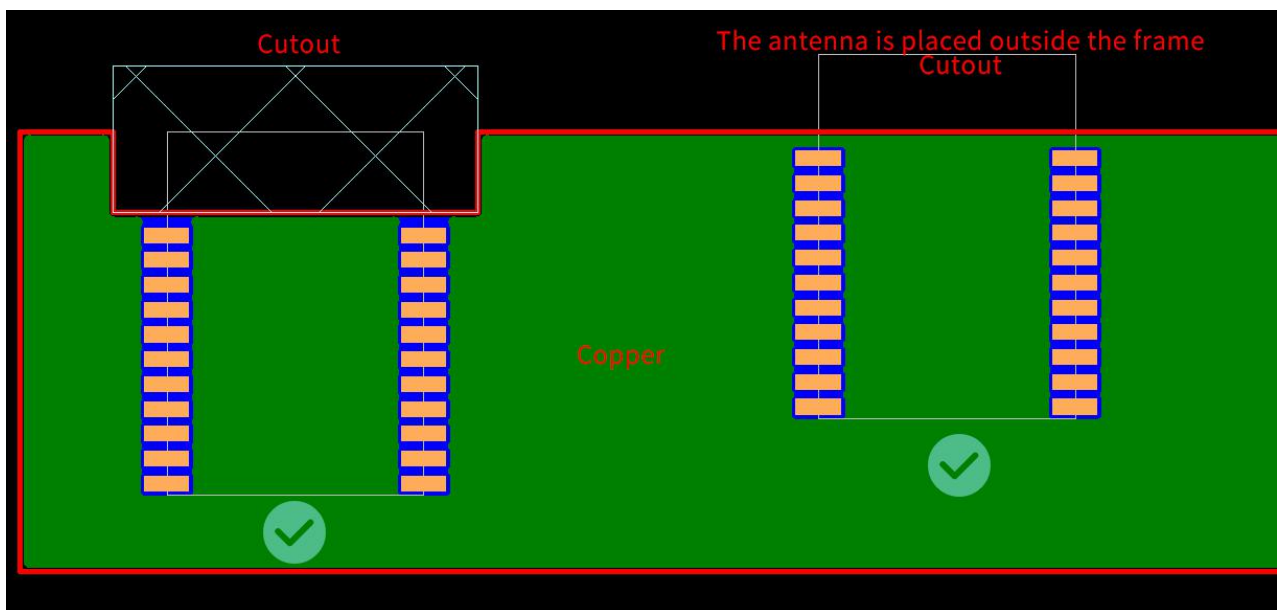

(Not recommend)

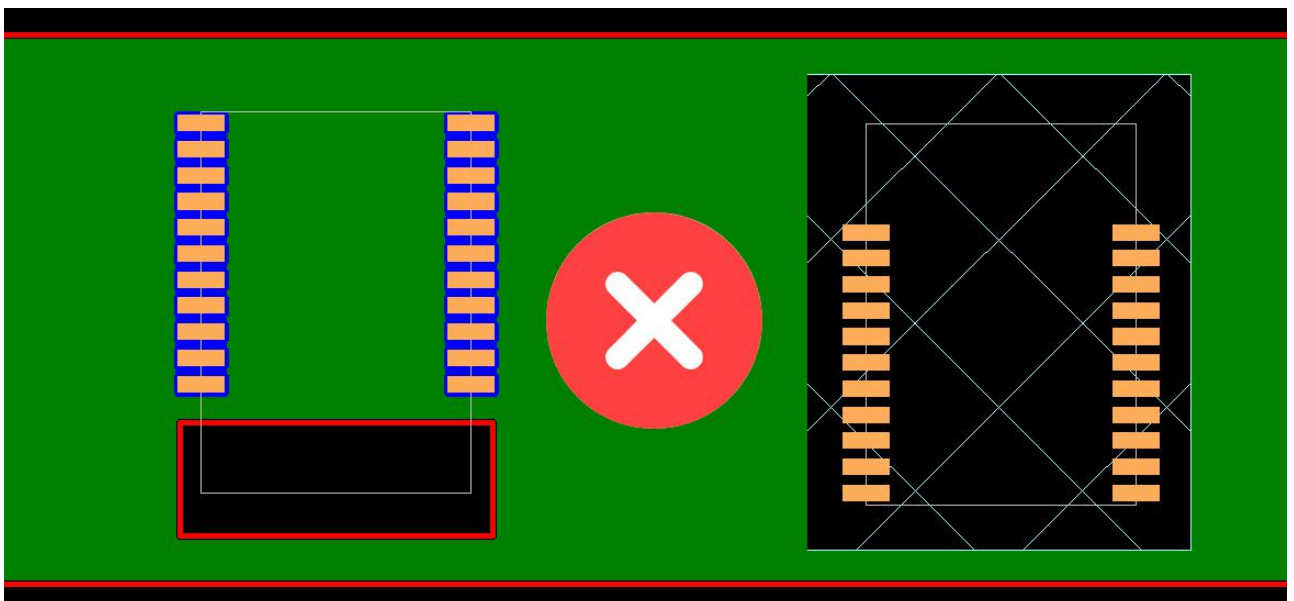



## 12. AT COMMAND

### (Note: AT command mode when the module is not connected)

1. AT command, which belongs to the character line instruction, is parsed according to the line (that is, AT command must be returned by carriage return or `\r\n`, hexadecimal number is 0D0A)
2. The AT command supports case and the instruction prefix is AT+, which can be divided into parameter setting instructions and read instructions.
3. Set the instruction format: AT+<CMD><PARAM> Operation returns successfully: +<CMD>=<PARAM>\r\n OK\r\n Failure does not return characters. **In addition to the 6th and 7th settings, the other parameters need to be restarted after setting the parameters for the new parameters to take effect.**
4. Read instruction format: AT+<CMD>Operation succeeds: +<CMD>=<PARAM>\r\n Failure does not return a return character.

AT command format example (Figure 1 is AT test command, Figure 2 is to change the Bluetooth name to 1234):

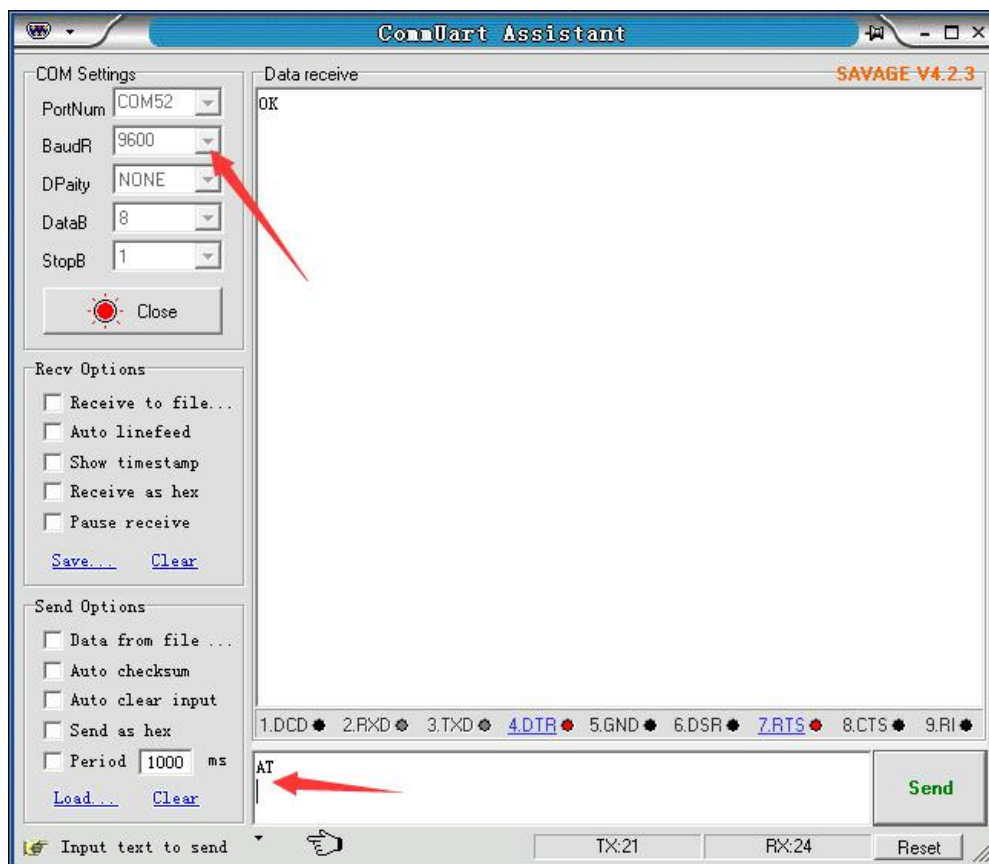



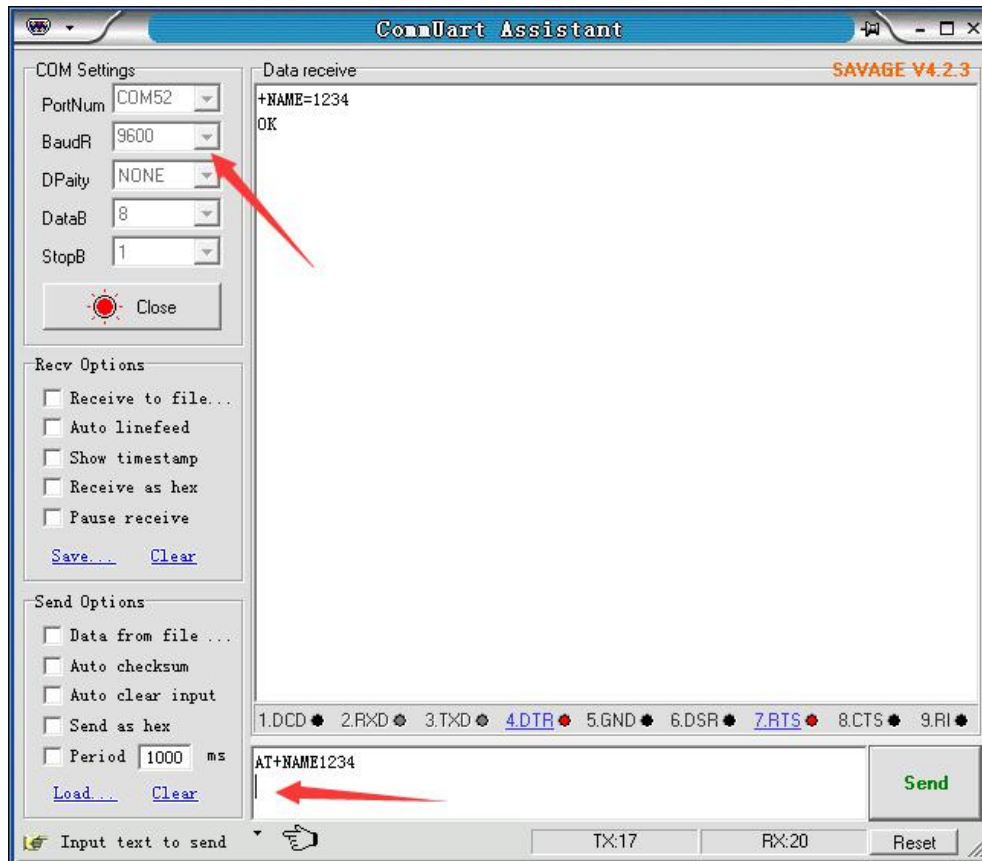

**1、 Test Command:**

Function	Command	Response	Description
Test instructions	AT\r\n	OK\r\n	

**2、 Get The Software Version:**

Function	Command	Response	Description
Query version number	AT+VERSION\r\n	+VERSION=<version>\r\n OK\r\n	<version > Software version number

Note:The version will be different depending on different modules and customization requirements.

**3、 Query Module Bluetooth MAC:**

Function	Command	Response	Description
Query module MAC address	AT+LADDR\r\n	+LADDR=<laddr>\r\n	<laddr> Bluetooth 12-bit MAC Address Code



#### 4、Set/Query Device Name:

Function	Command	Response	Description
Query module Bluetooth name	AT+NAME\r\n	+NAME=<name>\r\n	<name> Bluetooth name, up to 20 bytes
Set the module Bluetooth name	AT+NAME<name>\r\n	+NAME=<name>\r\n OK	Default name: BT24

#### Example:

##### 1. Send Settings:

AT+NAME=DX-BT24\r\n ——Set module device name: “DX-BT24”

return:

+NAME=DX-BT24\r\n ——Set module device name: “DX-BT24” succeeded  
OK\r\n

##### 2. Send inquiry:

AT+NAME\r\n ——Query module name

return:

+NAME=DX-BT24\r\n ——Return module device name: “DX-BT24”

#### 5、Set/Query - Serial Port Baud Rate:

Function	Command	Response	Description
Query module baud	AT+BAUD\r\n	+BAUD=<baud>\r\n	<baud> Baud rate corresponding serial number 1:2400 2:4800 3:9600 4:19200 5:38400 6:57600 7:115200 8:230400 Default: 3(9600)
Set the module baud	AT+BAUD<baud>\r\n	+BAUD=<baud>\r\n OK\r\n	

**Note:** The module must be re-powered after setting the baud rate, enabling the new baud rate for data communication and AT command resolution.

**Example:** Setting the Serial Port Baud Rate: 57600

##### 1. Send Settings:

AT+BAUD6\r\n



return:

+BAUD=6\r\n  
OK\r\n

2. Send inquiry:

AT+BAUD?\r\n

return:

+BAUD=6\r\n  
OK\r\n

#### 6、Set/Query - Serial Port Stop Bit:

Function	Command	Response	Description
Query module serial port stop bit	AT+STOP\r\n	+STOP=<Param>\r\n	< Param> Stop bit 0 -1 Stop bit
Set module serial port stop bit	AT+STOP<Param >\r\n	+STOP=<Param>\r\n OK	1 -2 Stop bit Default: 0

#### 7、Set / Query - Serial Parity Bit:

Function	Command	Response	Description
Query module serial parity bit	AT+PARI\r\n	+PARI=<Param>\r\n	< Param> Check Digit 0 -1 No check
Set the module serial parity bit	AT+PARI<Param >\r\n	+PARI=<Param>\r\n OK	1 -2 Odd parity 2 -2 Even parity Default: 0

#### 8、Set/Query—Notify the host computer connection status : The connection success module returns OK+CONN:

Function	Command	Response	Description
Query status	AT+NOTI\r\n	+NOTI=<Param>\r\n	< Param> Check Digit 0- Not notified
Set status	AT+NOTI<Param >\r\n	+NOTI=<Param>\r\n OK	1- Notice Defaults: 0

#### 9、Set/Query—Notification connection with address code: The connection success module returns OK+CONN0x112233445566:

Function	Command	Response	Description
Notification connection	AT+NOTP\r\n	+NOTP=<Param>\r\n	< Param> Check Digit



with address code			0- Not notified
Notification connection	AT+NOTP<Para	+NOTP=<Param>\r\n	1- Notice
with address code	m>\r\n	OK	Defaults: 0

#### 10、Settings\Query—SERVICE UUID:

Function	Command	Response	Description
Query service UUID	AT+UUID\r\n	+UUID =<service>\r\n	<service> UUID
Set service UUID	AT+UUID<service>\r\n	+UUID =<service>\r\n OK	Default service UUID: FFE0

**Example:** Set the service UUID to: FE00

1. Send Settings:

```
AT+UUID0XFF00\r\n
```

return:

```
+UUID=0XFF00 r\n
```

```
OK
```

#### 11、Settings\Query—NOTIFY UUID\ WRITE UUID:

Function	Command	Response	Description
Query module notify\write UUID	AT+CHAR\r\n	+CHAR=<UUID >\r\n	<UUID>notify\write UUID
Set module notify \write UUID	AT+CHAR<UUID>\r\n	+CHAR =<UUID>\r\n OK	Default: FFE1

**Note:** This channel is a readable and writable channel (ie it can be read or written)

Example: Set the notify \write UUID to: FE01

1. Send settings:

```
AT+CHAR0XFE01\r\n
```

return:

```
+CHAR= FE01r\n
```

```
OK\r\n
```

#### 12、Settings\Query—WRITE UUID:

Function	Command	Response	Description
Query module write UUID	AT+WRITE\r\n	+WRITE=<UUID >\r\n	<UUID> write UUID Default: FFE2



Set module write UUID	AT+WRITE<UUID>\r\n	+WRITE=<UUID>\r\n OK	
-----------------------	--------------------	-------------------------	--

**13、Settings\Query - Low Power Mode:**

Function	Command	Response	Description
Query module low power mode	AT+PWRM\r\n	+PWRM=<Param>\r\n	< Param >(0、 1) 0: Low power mode
Set module low power mode	AT+PWRM<Param>\r\n	+PWRM=<Param>\r\n OK	1: working mode Default: 1

**14、Settings\Query - Broadcast time interval:**

Function	Command	Response	Description
Query Broadcast time interval	AT+ADVI\r\n	+ADVI=<Param>\r\n	Param: 0~F 0—100ms 1—152.5ms 2—211.25ms 3—318.75ms 4—417.5ms 5—546.25ms 6—760ms 7—852.5ms 8—1022.5ms 9—1285ms A—2000ms B—3000ms C—4000ms D—5000ms E—6000ms F—7000ms Default: 5
Set Broadcast time interval	AT+ADVI<Param>\r\n	+ADVI=<Param>\r\n OK	

**Note: This instruction can be used to reduce power consumption**

**15、Settings\Query - Module transmit power:**

Function	Command	Response	Description
----------	---------	----------	-------------



Query module transmit power	AT+POWE\r\n	+POWE=<POWE>\r\n	<POWE>: 1: -19.5 dB 2: -13.5 dB
Set module transmit power	AT+POWE<POWE>\r\n	+POWE=<POWE>\r\n OK\r\n	3: -10dB 4: -7dB 5: -5dB 6: -3.5dB 7: -2dB 8: -1dB 9: 0dB A: +1dB B: +1.5dB C: +2.5dB  Default: C

**16、 Software restart:**

Function	Command	Response	Description
Software restart	AT+RESET\r\n	OK\r\n	

**17、 Restore default settings:**

Function	Command	Response	Description
Restore default settings	AT+DEFAULT\r\n	OK\r\n	

**13. Contact us**

**Shen Zhen DX-SMART Technology Co., Ltd.**

**Address:** 511 ,Building C, Yuxing Technology Park, Yuxing Chuanggu, Bao'an District, Shenzhen, China

**Tel:** 0755-2997 8125    **Fax:** 0755-2997 8369

**Website:** <http://www.szdx-smart.com/>